

CSN840 Pallet™

Optimizing pallet handling



Wide measuring capabilities

for handling a large range of goods from small to big pallets, as well as dark or glossy wrapping, with the highest accuracy. Irregularities such as protrusions sticking out will also be included in the dimensions, securing a correct data foundation.



Seamless integration

to any location and traffic on the floor. Ceiling, floor or wall-mounting options enable the user to find a suitable location that optimizes pallet throughput and does not interfere with current operations. Pallets can be placed beneath the dimensioner from any direction.



All pallet data in one go

with dimensions, weight and identification automatically collected and processed to host in one single string. The modular system allows for different configurations to meet customer needs. Users can choose the components and software modules that suit their application.



Easy to operate

with a user-friendly work-station. Data collection is initiated by scanning the bar code. The data is instantly displayed on the monitor and a traffic light shows the status of the measuring process. The operator has full control at all times, of both current and historical data on the screen.

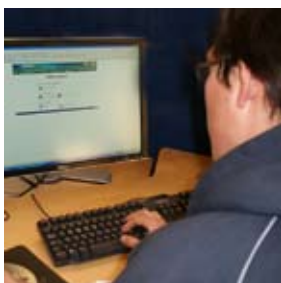

Service web-page

for each unit. Installation, maintenance and upgrades are quick and easy through Internet, both remote and on-site. A user-friendly interface guides the user through the different commands of the system, reducing the need for advanced training and maximizing system capabilities and up-time.



CSN840 Pallet™ Static pallet solution

The CSN840 Pallet™ is the first fully approved pallet measuring system with high accuracy on all shapes and surfaces.

The CSN840 Pallet™ is ideal for improving pallet handling processes in goods terminals, pallet drop-off centres, shipping docks and warehouses. Modular design means the system can be combined with any floor or forklift scale. The overhead dimensioning scanners can be floor, wall or ceiling-mounted. Captured data is wirelessly connected to a customer's host computer system for manifesting and optimum revenue protection.

The CSN840 Pallet™ guarantees full data integrity with well proven laser range finder technology and world wide weights and measures approvals.

CSN840 Pallet™

Static pallet solution

Features and benefits

- Laser range finder technology for accurate measurement of length, width and height
- Wireless long-range, hand held bar code reader for automatic ID
- 20 mm accuracy for reliable measurements
- Ceiling, floor and wall mounting options for seamless integration
- Merging software for secure collection and linking of data
- Host communication for seamless transfer of data to customer host
- Image capture of pallets for protection against damage claims and audits
- Bar-code validation for customization of bar codes to accept or reject
- Alibi memory for tamper-proof storage of data
- Web-page with graphical menu for quick set up, easy configuration, monitoring and access to statistics
- Embedded application software. No extra PC required.
- Remote access. Easy upgrades and service
- DimCentral™ monitoring for immediate fault reporting and performance surveillance
- Graphical colour user-interface and monitor for clear overview of measuring process
- Traffic light to guide the operator
- CS2200LX display for legal for trade applications
- Taring functionality to separate load from the pallet
- MID, NTEP and Canadian MC Approvals for ensured data quality

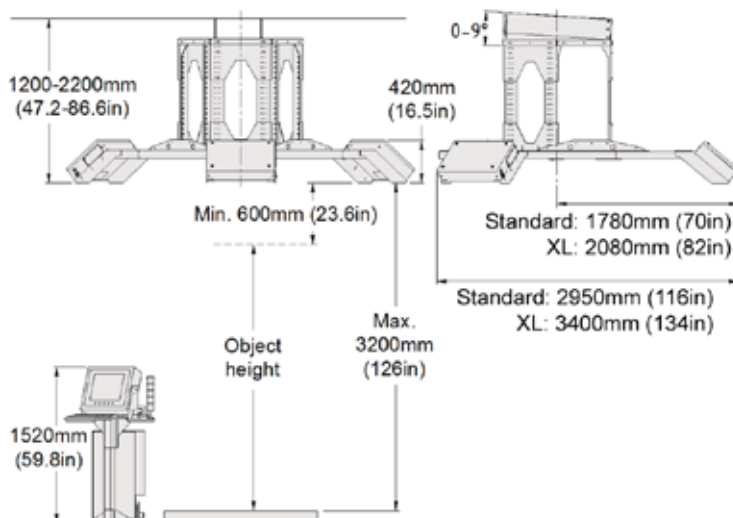

Specifications

| | |
|-------------------------|--|
| Dimensioning accuracy | ± 20 mm |
| Maximum size (LxWxH) | Standard version: 1830 x 1830 x 2600 mm XL version: 2500 x 2500 x 2600 mm |
| Minimum size (LxWxH) | 200 x 200 x 200 mm ¹⁾ |
| Maximum weight | Depending on floor scale |
| Minimum weight | Depending on floor scale |
| Throughput | Approx. 200 pallets pr/hr depending on how pallets are handled in the terminal |
| Shape | All solid shapes ²⁾ |
| Surface characteristics | Most surfaces. Variance are sometimes encountered when surface is transparent/translucent or very glossy ³⁾ |
| Orientation | Place pallet within the defined field of view |
| Background | Flat continuous surface. Instrument verifies acceptable background. |
| Spacing | Objects placed under the dimensioner one-by-one |
| Operational temperature | 0° to 40 °C |
| Power | 230 V 50 Hz, or 100-115 V 60 Hz |
| Laser type | Class 2 |
| Interface | General Ethernet (TCP/IP) or Standard host (RS232) |
| I/O ports | VGA, USB, keyboard, binary in, binary out |

1) Legal for trade approved at 200 x 200 x 200 mm (8 x 8 x 8 in.)
 2) Protrusions < 7.5 cm may be ignored and not included in the dimensions
 3) System gives message code if surface looks uncertain

Main components

| | |
|----------------------|--|
| Dimensioner | CSN840.3 |
| Scale -standard | IND425- Vertex 2158 for 6000 kg (13000lb) or 3000 kg (6500lb) |
| -option | IND425-ES3000/A for 3000 kg or IND425-ES1500/A (3250 lb) |
| Bar code reader | Datalogic Gryphon, long range |
| Accessories | Colour TFT-LCD 17" monitor, touch screen, standard USB keyboard, workstation, power management kit, traffic light and various stands |
| Application software | host communication, bar code validation, alibi memory, remote diagnostics |

Hardware and software components can be purchased separately or as a complete certified dimensioning, weighing and identification solution.



OIML 129, MID and NTEP certificates
 Compliant to health and safety regulations
 Internet: <http://www.mt.com>
 Worldwide service
 Quality certificate ISO9001



Subject to technical changes
 © 11/2009 Mettler-Toledo Cargoscan AS
 Printed in Norway 790097
 CSN MarCom Oslo

www.mt.com/CSN840

Visit for more information